

**Part Number: PZ41B-X2620-00
PZ41B-X2622-00**

Kit Contents (see next page for description)

| Item # | Quantity Req'd. | Description |
|--------|-----------------|-----------------------|
| 1 | 1 | Front cross bar |
| 2 | 1 | Rear cross bar |
| 3 | 2 | Cross bar rubber trim |
| 4 | 4 | Key |
| 5 | 2 | 3-hole 3M film |
| 6 | 2 | 2-hole 3M film |
| | | |

Hardware Bag Contents

| Item # | Quantity Req'd. | Description |
|--------|-----------------|-------------|
| | | |

Additional Items Required For Installation

| Item # | Quantity Req'd. | Description |
|--------|-----------------|-------------|
| | | |

Conflicts

| |
|--|
| |
|--|

Recommended Tools

| Personal & Vehicle Protection | Notes |
|--|------------------------------|
| Blankets | Protect the roof |
| | |
| | |
| Special Tools | Notes |
| Non-intrusive Infrared Temp Probe/Gun | |
| | |
| | |
| Installation Tools | Notes |
| Scissors | |
| | |
| | |
| Special Chemicals | Notes |
| Cleaner | VDC Approved Surface Cleaner |
| Soap & water solution | |
| | |

General Applicability

| |
|--|
| |
|--|

Recommended Sequence of Application







| Item # | Accessory |
|--------|-----------|
| 1 | |
| 2 | |
| 3 | |
| | |

*Mandatory

Vehicle Service Parts (may be required for reassembly)

| Item # | Quantity Req'd. | Description |
|--------|-----------------|-------------|
| 1 | | |
| 2 | | |
| 3 | | |
| | | |

Legend

| | |
|--|--|
|  | STOP: Damage to the vehicle may occur. Do not proceed until process has been complied with. |
|  | OPERATOR SAFETY: Use caution to avoid risk of injury. |
|  | CAUTION: A process that must be carefully observed in order to reduce the risk of damage to the accessory/vehicle and to ensure a quality installation. |
|  | TOOLS & EQUIPMENT: Used in Figures calls out the specific tools and equipment recommended for this process. |
|  | REVISION MARK: This mark highlights a change in installation with respect to previous issue. |
|  | SAFETY TORQUE: This mark indicates that torque is related to safety. |

Care must be taken when installing this accessory to ensure damage does not occur to the vehicle. The installation of this accessory should follow approved guidelines to ensure a quality installation.

These guidelines can be found in the "Accessory Installation Practices" document.

This document covers such items as:-

- Vehicle Protection (use of covers and blankets, cleaning chemicals, etc.).
- Safety (eye protection, rechecking torque procedure, etc.).
- Vehicle Disassembly/Reassembly (panel removal, part storage, etc.).
- Electrical Component Disassembly/Reassembly (battery disconnection, connector removal, etc.).

Please see your Lexus dealer for a copy of this document.

1. Prepare for Installation.

(a) Verify the kit contents (Fig. 1-1).

- (1) A = Front cross bar
- (2) B = Rear cross bar
- (3) C = Cross bar rubber trim (2 pcs)
- (4) D = Keys (4 pcs)
- (5) E = 3-hole 3M film (2 pcs)
- (6) F = 2-hole 3M film (2 pcs)

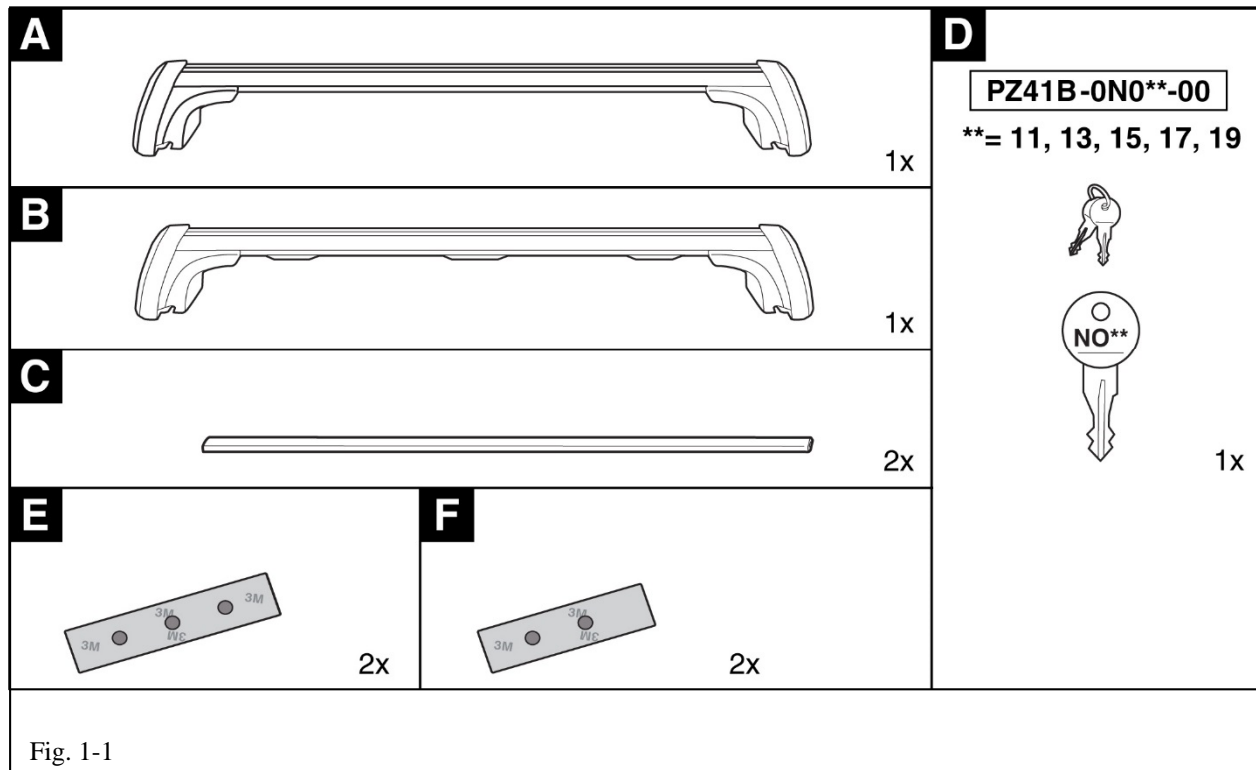
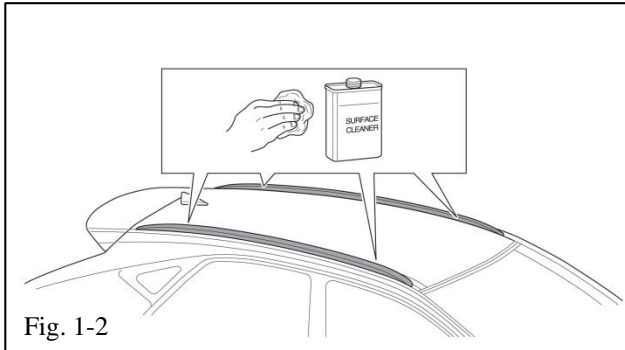

Fig. 1-1

- (b) The surface temperature should be between 65°F and 100°F for optimum installation. The vehicle needs to be dry as well.
- (c) Protect the roof with a blanket.
- (d) Clean the mounting area as indicated with VDC-approved cleaner (Fig. 1-2).



2. Prepare to Install the Cross Bars.

- (a) Apply the 3 hole clear 3M film strip to the front 3 holes located at the inside of both roof rails (Fig. 2-1).

⚠ HINT: Peel the backing about halfway and line the strip up to the front hole (Fig. 2-2). Progressively peel the backing and apply the strip the rest of the way.

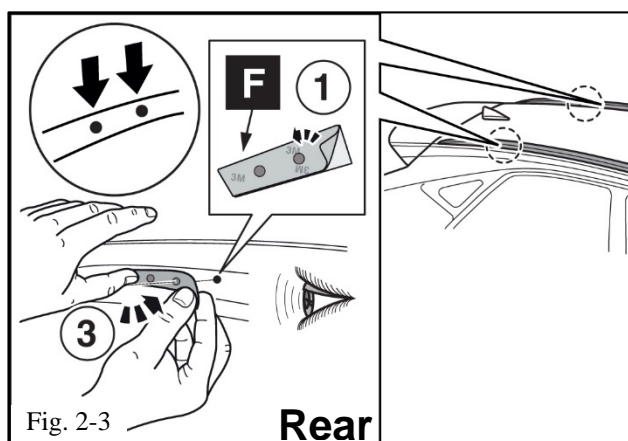
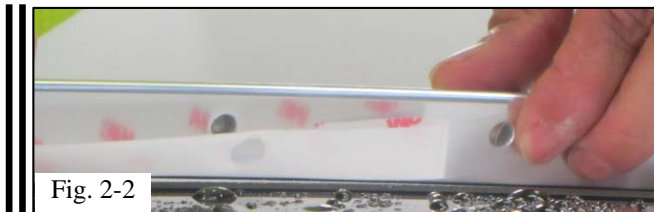
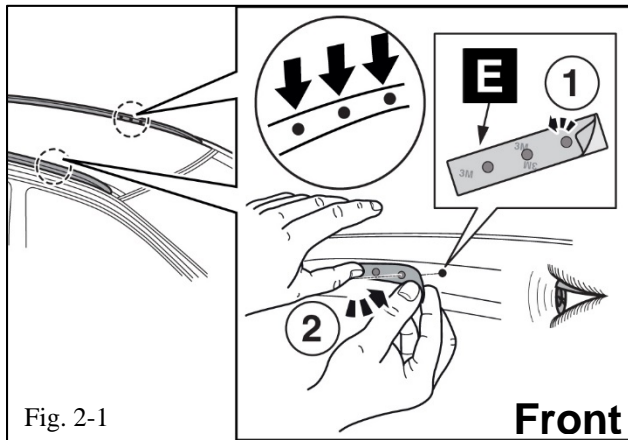

- (b) Apply the 2 hole clear 3M film strip to the rear 2 holes located at the inside of both roof rails (Fig. 2-3).
- (c) Remove the keys from the clear plastic bag. Retain the plastic bag for storing the keys.

⚠ NOTE: Open the bag neatly for reuse.

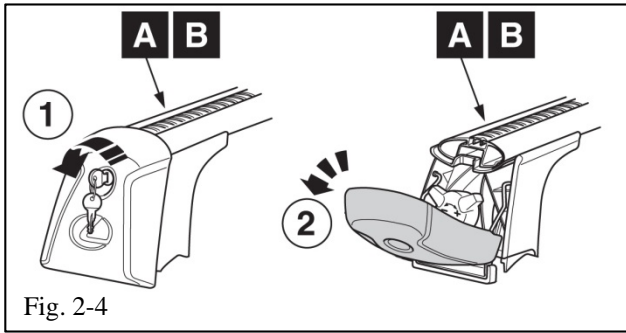

(d) Insert the key to unlock and open the end covers (Fig 2-4). Leave the keys in the locks until the installation is complete.

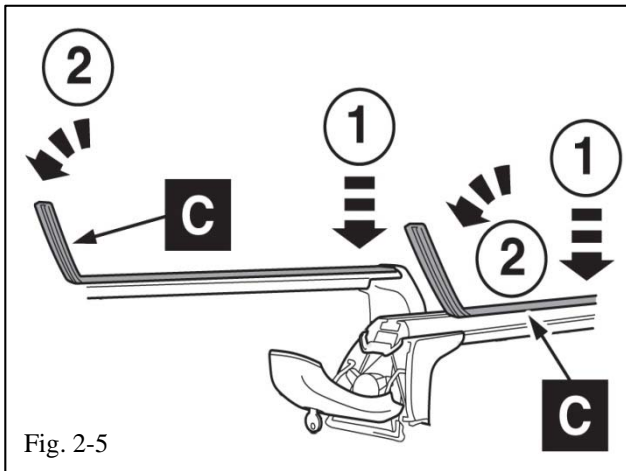

(e) Spray the rubber trim (C) with soap and water solution if needed.

(f) Install the rubber trim (C) into the top of the cross bar assemblies (Fig. 2-5).

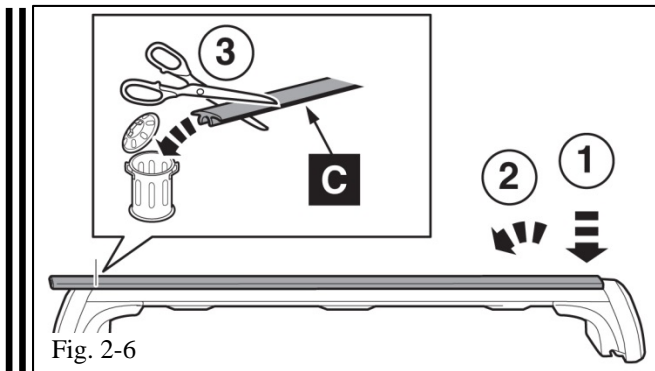

(g) Cut the ends of the rubber trim strip (C) flush with the end of the rail (Fig. 2-6).

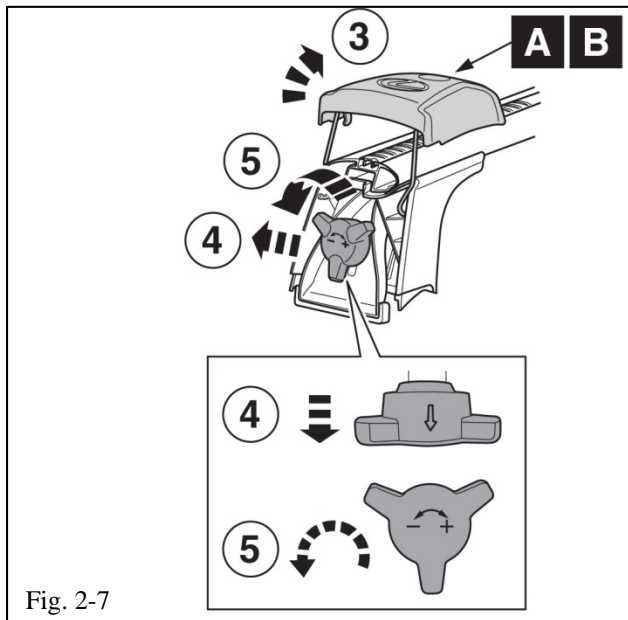

- (h) Swing the end covers up on top of the cross bar (Fig. 2-7).
- (i) Pull the adjustment knobs out and turn counterclockwise to loosen the assembly enough to allow for installation (Fig. 2-7).

NOTE: The knob will come off if loosened all the way.

3. Install the Front Cross Bar.

- !** (a) Be sure to use 2 people (Fig. 3-1).
- !** (b) Do not move or slide the cross bar along the vehicle side rails.

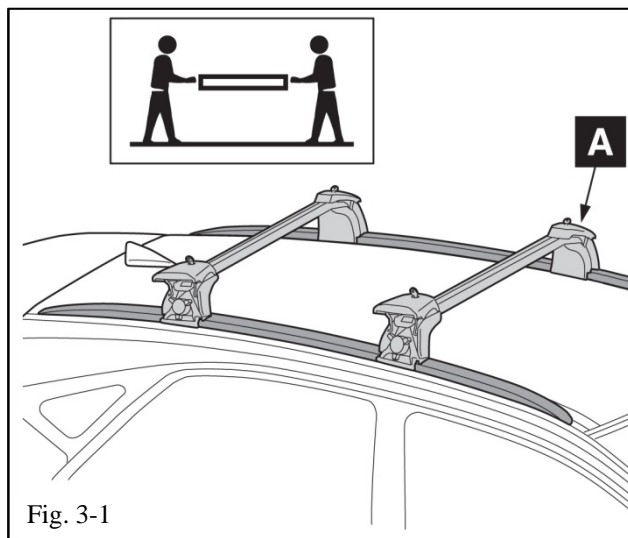

- (c) The bars are identified by a sticker on each support (Fig. 3-2). Make sure to place the support at the proper location on the vehicle.

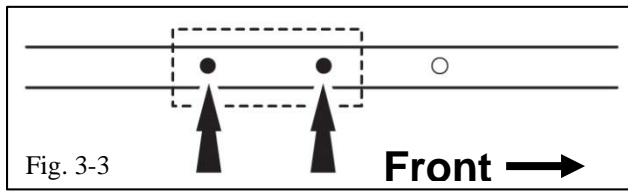

⚠ (d) Place the front cross bars into the two rearward holes in the side rails (Fig. 3-3).

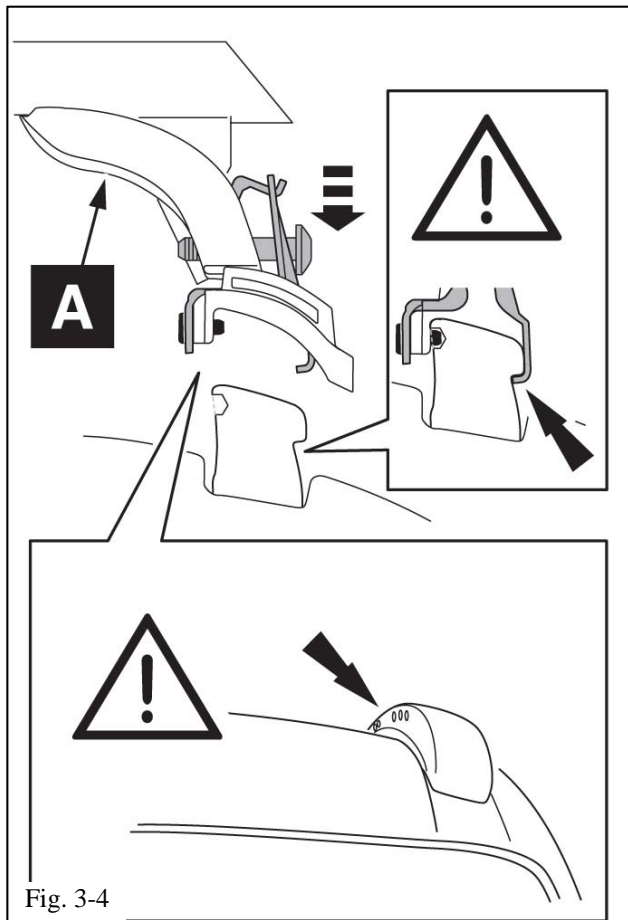

⚠ (e) Ensure that the cross bar supports are placed properly into the side rail assembly by making sure the clamp is under the outer rail edge and the locating pins are fully seated into the holes in the side rail assembly (Fig. 3-4).

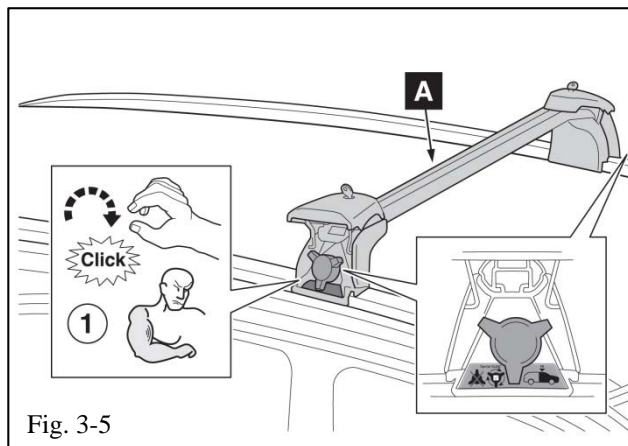

(f) Tighten the passenger's side adjustment knob until it clicks (Fig. 3-5).

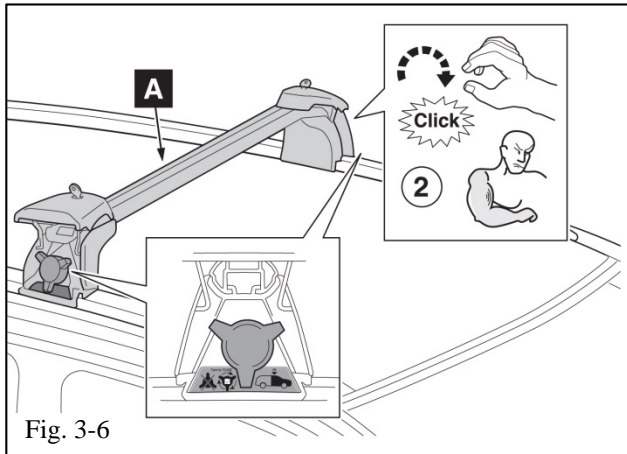

(g) Tighten the driver's side adjustment knob until it clicks (Fig. 3-6).

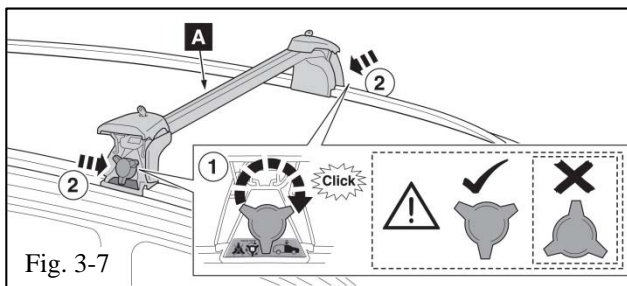

⚠ (h) After the first click, turn the knobs clockwise until they point down (Fig. 3-7).

(i) Push the knobs inwards as far as possible.

4. Install the Rear Cross Bar.

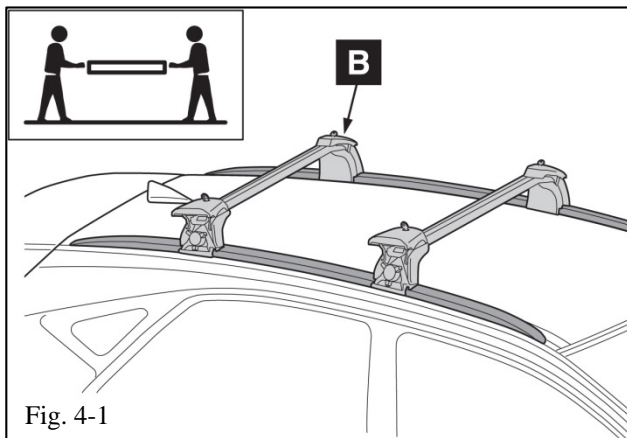

⚠ (a) Be sure to use 2 people (Fig. 4-1).

⚠ (b) Do not move or slide the cross bar along the vehicle side rails.

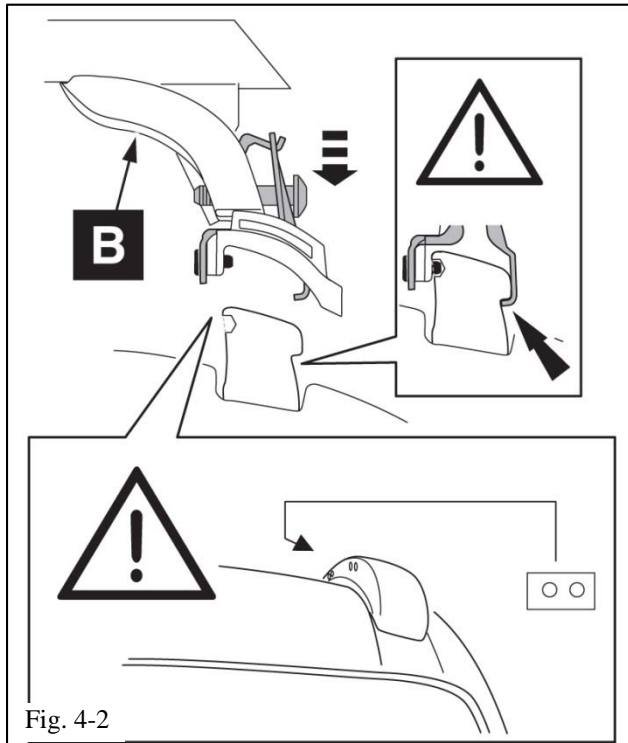

- ⚠ (c) Ensure that the cross bar supports are placed properly into the rail assembly by making sure the clamp is under the outer rail edge and the locating pins are fully seated into the holes in the rail assembly (Fig. 4-2 & Fig. 4-3).

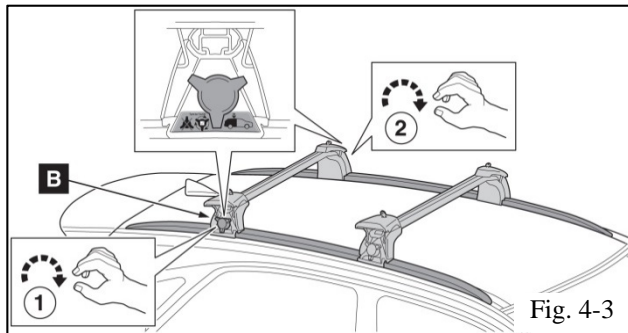

- (d) Tighten the passenger's side adjustment knob until it clicks (Fig. 4-4).

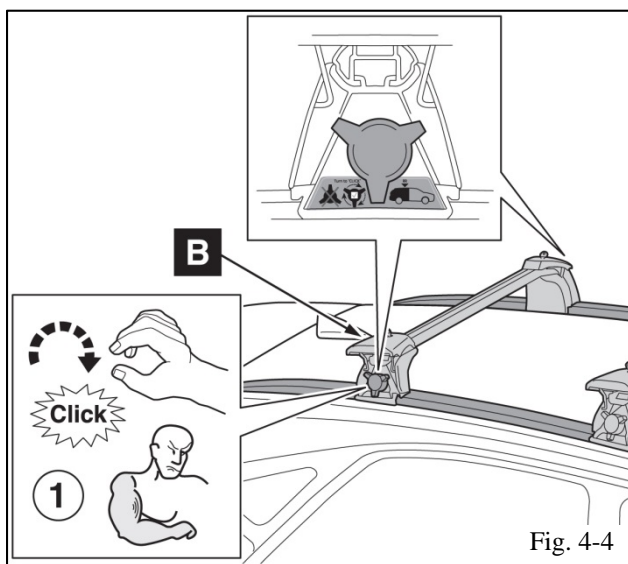

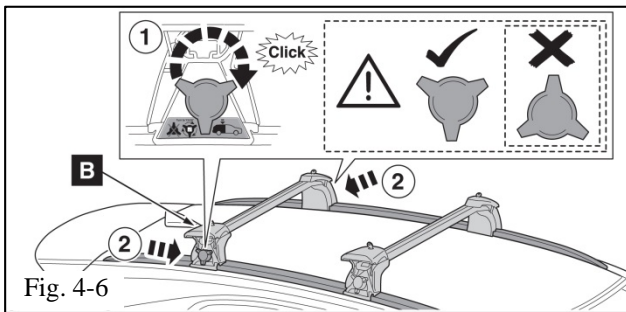
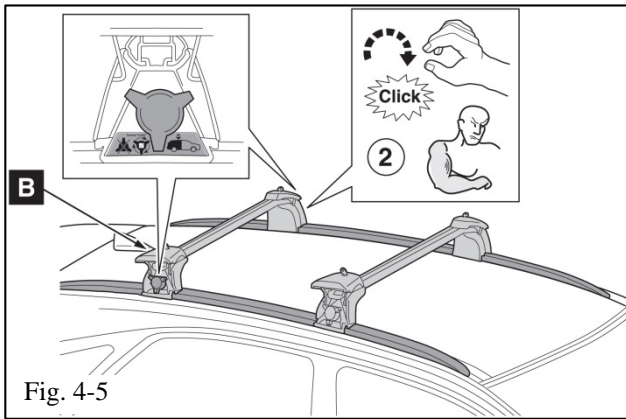

(e) Tighten the driver's side adjustment knob until it clicks (Fig. 4-5).

(f) After the first click, turn the knobs clockwise until they point down (Fig. 4-6).

(g) Push the knobs inwards as far as possible.

5. Complete the Installation.

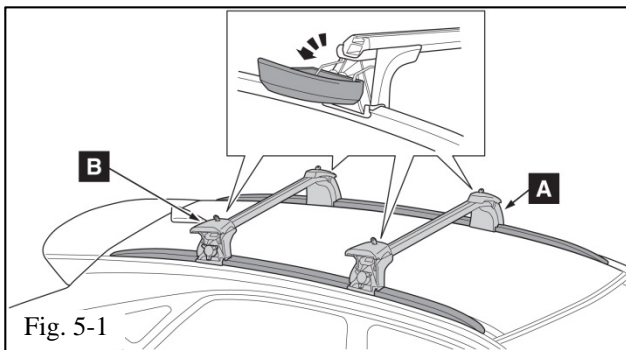

(a) Swing the end caps down (Fig. 5-1).

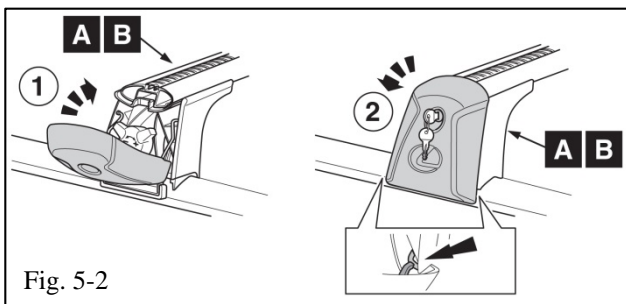

(b) Close and lock the end caps (Fig. 5-2).

(c) Ensure the end caps are securely in place by pulling on the top edge.

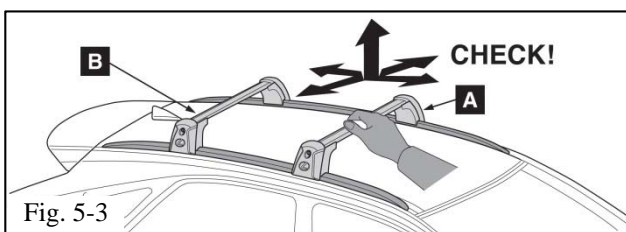

(d) Check that the cross bars are tight and do not move (Fig. 5-3).

(e) Remove the 4 keys, place them in the original plastic bag and then place the bag with the keys in the glove compartment.

Checklist - these points **MUST** be checked to ensure a quality installation.

| <u>Check:</u> | <u>Look For:</u> |
|--|--|
| <p><u>Accessory Function Checks</u></p> <ul style="list-style-type: none"> <input type="checkbox"/> Ensure the cross bars are secure and in correct position  <input type="checkbox"/> Ensure the covers are securely attached <input type="checkbox"/> Ensure the keys are in glove compartment <input type="checkbox"/> | <ul style="list-style-type: none"> Cross bar knobs are tight and the front bars are in the rear 2 holes Covers are securely in place and locked Keys should be in the glove compartment |
| <p><u>Vehicle Function Checks</u></p> <ul style="list-style-type: none"> <input type="checkbox"/> <input type="checkbox"/> <input type="checkbox"/> | |
| <p><u>Vehicle Appearance Check</u></p> <ul style="list-style-type: none"> <input type="checkbox"/> After accessory installation and removal of protective cover(s), perform a visual inspection. | <p>Ensure no damage (including scuffs and scratches) was caused during the installation process. (For PPO installations, refer to TMS Accessory Quality Shipping Standard.)</p> |